

# BEYOND VISION

NEWTOM  
RX DC  
Wireless



**NEWTOM**

CONE BEAM 3D IMAGING



# RX DC INTRAORAL X-RAY UNIT

Outstanding quality and innovation, exceptional features.

## NEWTOM RX DC WIRELESS

- RX DC efficiency stems from a combination of advanced technology and an outstanding capacity to produce high definition images. The RX DC X-ray unit provides top-flight performance, practicality and technology.
- The RX DC features a constant potential high frequency (DC) generator and a very small focal spot (0.4 mm) capable of providing sharp, detailed images while ensuring working comfort and low doses for the patient.
- Higher performance with RX DC, the X-ray unit that combines high definition imaging, ergonomic design and low X-ray doses.

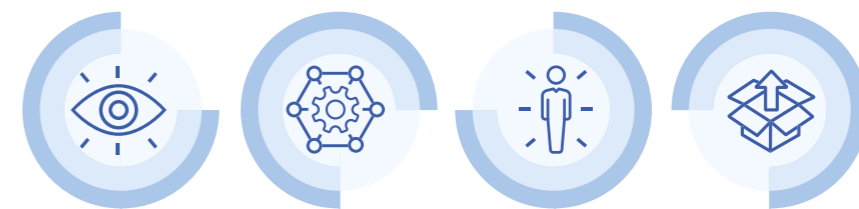

<p><b>SUPERIOR DIAGNOSTIC QUALITY</b></p> <p>Obtained in just a few simple steps, all images are high resolution.</p>	<p><b>ADVANCED TECHNOLOGY</b></p> <p>The NEWTOM RX DC high-frequency X-ray unit is based on NEWTOM's know-how with a 30 cm source distance and 0.4 mm focal spot.</p>	<p><b>MINIMAL RADIATION DOSE</b></p> <p>Thanks to rectangular collimation and the ECO Mode parameters, the patient exposure to X-rays is minimal.</p>	<p><b>VERSATILE AND EASY TO INSTALL</b></p> <p>Easy, fast installation with multiple positioning options. NEWTOM RX DC is available in both a wall-mounted and a trolley-mounted version.</p>
---	---	---	---

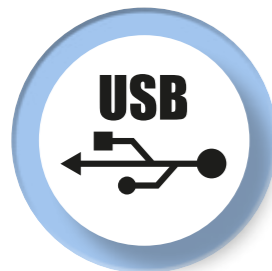

### USB CONNECT\*

With USB Connect technology, RX DC communicates directly with the PC via a USB port. Integrated with the X-ray log, the system allows the delivered dose data to be digitally recorded and then associated with the patient's NNT-managed medical record. Dentists can display dose values, monitor them over time and send them to other applications via shared files.

\*Optional



### WIRELESS USER-FRIENDLY CONTROL

A practical, user-friendly wireless handheld unit, designed for immediate, precise X-ray image acquisition, allows easy selection of the most suitable programme. Moreover, it allows users to control the exact emitted dose and the tube temperature via the sequential exposure graph.

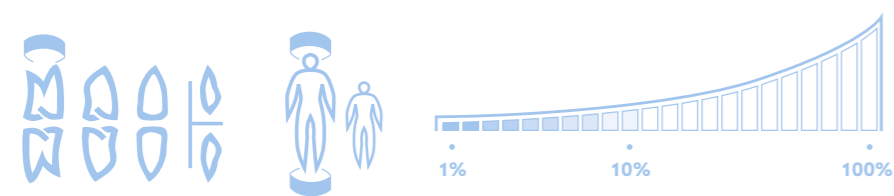

## PRECISION DIAGNOSTICS

### Immediate diagnosis, excellent results.

Focal spot 0.4 mm and power 70 kV, 8 mA, high-frequency constant potential generator. Cutting-edge technology for extremely detailed images. The RX DC is extremely reliable: constant-potential design ensures image generation is unaffected by power fluctuations.

### SUPERIOR PERFORMANCE AND TOP-CLASS ERGONOMICS.

Thanks to the protractor with graduated scale, positioning of the arms and the head is stable, effective and fully adaptable to your work. Consists of arms with an integrated self-balancing system - available in the following lengths: 40 cm (15.7") - 60 cm (23.6") - 90 cm (35.4"). The adjustable wall support ensures maximum installation versatility.

Increased X-ray parallelism and an incorporated collimator allow the RX DC to achieve a source-to-skin gap of 30 cm. The RX DC provides pin-sharp, precise images with outstanding detail.

Extremely practical and versatile, RX DC can be used together with any type of direct or indirect digital sensor and X-ray film. Featuring 28 levels of sensitivity, it ensures sharp images in any situation.

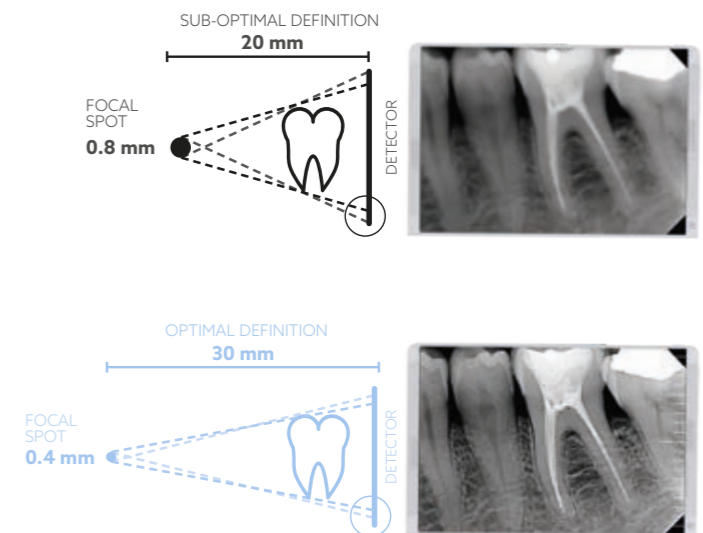

The RX DC unit can also be set up with shutters and an (optional) rectangular collimator to define the body area that will be exposed and so reduce the received dose. Maximum attention to staff and patient health, while ensuring sharp, high definition image quality.

### TROLLEY-MOUNTED VERSION

Maximised mobility for NEWTOM RX DC: a practical trolley allows the X-ray unit to be moved anywhere in the surgery.



**RX DC X-RAY UNIT**

Generator	Constant potential, microprocessor-controlled
Working frequency	145 - 230 KHz with self-adjustment (typically 175 KHz)
Focal spot	0.4 mm (IEC 336)
Total filtration	2 mm @ 60 kV / 2 mm @ 65 kV / 2 mm @ 70 kV (*)
Anode current	4 / 8 mA
Voltage at X-ray tube	60 / 65 / 70 kV (*)
Exposure times	0.020 - 1.000 seconds, R'10 and R'20 scale
Source-skin distance	20 and 30 cm
Irradiated field	Ø 60 mm and Ø 55 mm (with round cone)
Additional collimators	35 x 45 mm (with rectangular cone for size 2 sensors) 31 x 41 mm and 22 x 35 mm, for size 1 and size 0 sensors
Power supply	50/60 Hz, 115-120 V AC ±10% or 230-240 V AC ±10%
Duty Cycle	Continuous operation with self-adjustment up to 1s/90s total
Arms (for Standard version only)	Available in 3 lengths: 40 cm - 60 cm - 90 cm
Max arm extension	230 cm, from wall
Versions	Standard (wall mounted) or Mobile (on portable cart)
Dose delivered	Viewing on a handheld device with digital archive option on PC via NNT software which can be automated via the "USB connect" (optional) accessory
PC connection cable	Serial with USB adapter available in various lengths

(\*) values depend on the country where the product is marketed

**RX DC SOFTWARE**

Acquisition software (for PC)	iCapture for automatic archiving of RX DC exposure parameters on PC
Image management software (for PC)	NNT (compliant with ISDP®10003:2020 in accordance with EN ISO/IEC17065:2012 - certificate number 2019003109-3) and iPad NNT viewer App (free)
Protocols supported in NNT	DICOM 3.0, TWAIN, VDDS
DICOM Node Connectivity	NNT - IHE compliant (Print; Storage Commitment, SR document; WorkList; MPPS; Query/Retrieve)
X-ray log	NNT feature to associate exposure parameters with the X-ray images of each examination (exportable in PDF or CSV format)

**RX DC - MINIMUM SYSTEM REQUIREMENTS**

Supported operating systems	Microsoft® Windows® 10. 11 Professional 64 bit
Processor	Intel Core i3 or higher
Hard Disk	100 GB SSD (250 GB recommended)
RAM	4 GB (8 GB recommended)
Graphics card	Discrete 3D Video Card or integrated GPU
Display settings	1280 x 1024; 1344 x 768 or higher, 16 million colours
Port	USB 2.0 or later versions
Power supply	Use a power supply with suitable power for the video board in use

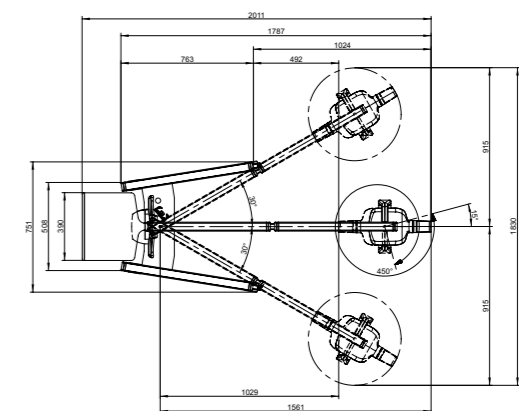
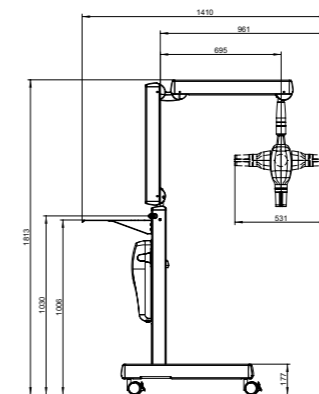
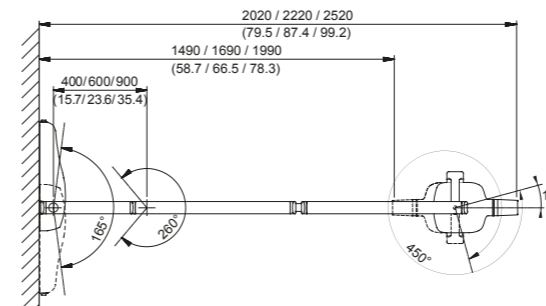
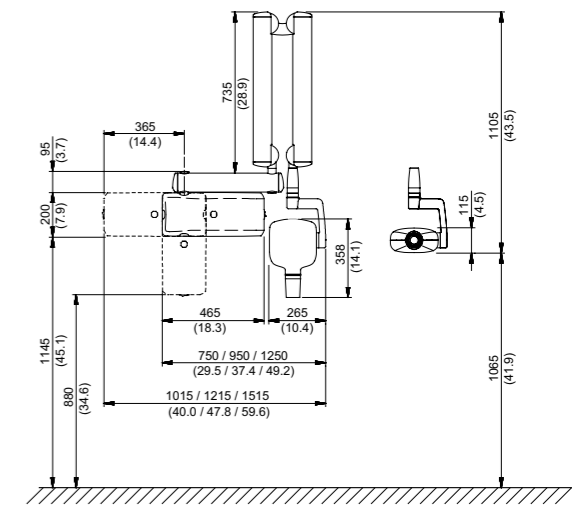
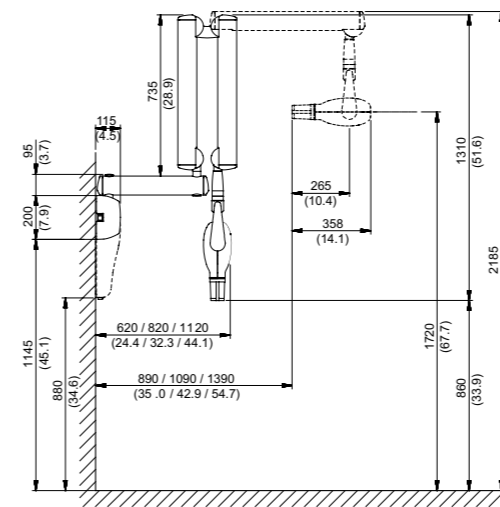

Dimensions in centimetres  
(dimensions in inches)

# NEWTOM

CONE BEAM 3D IMAGING



Making Your Life Better.

## BU MEDICAL EQUIPMENT

### SEDE LEGALE ED AMMINISTRATIVA HEADQUARTERS

Cefla s.c. - Via Selice Provinciale, 23/a  
40026 Imola - BO (Italy)  
tel. +39 0542 653111  
fax +39 0542 653344

### STABILIMENTO PLANT

Via Bicocca, 14/c  
40026 Imola - BO (Italy)  
tel. +39 0542 653441  
fax +39 0542 653601

### CEFLA NORTH AMERICA

6125 Harris Technology Blvd.  
Charlotte, NC 28269 - U.S.A.  
Toll Free: (+1) 800.416.3078  
fax: (+1) 704.631.4609

NRXDCWLLT251500

10/2025

The images and technical specifications shown in this catalog are for indicative purposes only.  
As part of ongoing technological updates, technical specifications may be subject to changes without prior notice.  
In accordance with current regulations, in non-EU areas some products, as well as certain technical specifications, may have different availability and configurations.  
We encourage you to always contact your local distributor for up-to-date technical specifications, availability and configurations.